

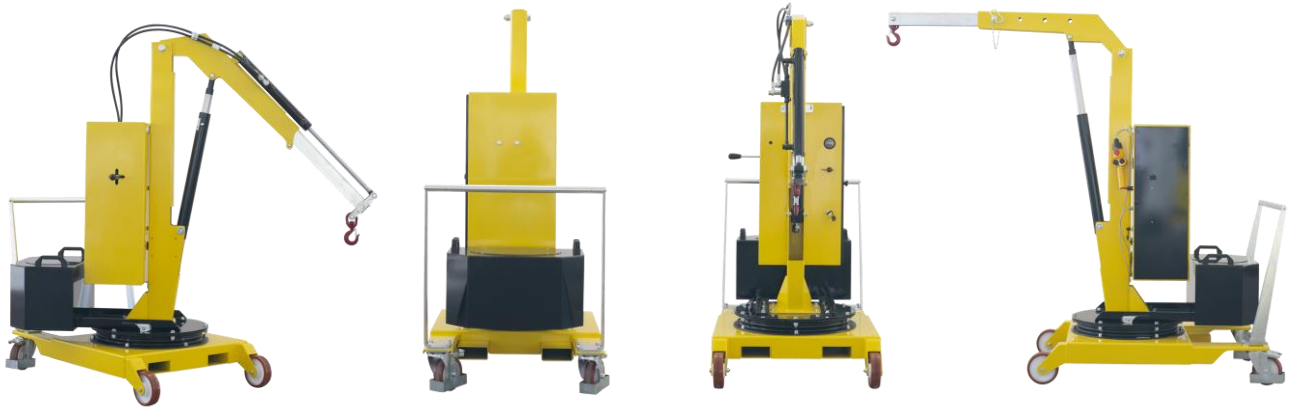

Flexibility, innovation
and safety
for your work

COUNTERBALANCED 360° SWIVEL CRANES



A complete range of counterbalanced 360° swivel cranes with manual traction. Hydraulic lever controlled or electric controlled. They represent the most cost-effective and flexible solution for lifting and transporting loads in several applications such as machining centers and machine tools, delivery to assembly lines, assembly operations, goods handling. Thanks to their compact dimensions they are easily maneuverable even at full load and can be moved effortlessly in confined spaces. All components are made in Italy to ensure the highest construction quality and the absence of defects.

The hydraulic system is equipped with a lock valve that prevents the load from falling in case of accidental breakage of the pipes and a rough valve that prevents overloading of the crane.

They are equipped with 2 high-capacity pivoting wheels with bumper mounts and parking brakes and with 2 fixed front wheels with bearings. The frame is made of painted steel and is equipped at the base with 2 useful forklift supports (to lift and transport the crane in complete safety on long distances). The sturdy push handle can be disassembled. There are also 2 handles to easily rotate the ballast. Swivel hook type. Rotating jib arm with 8 locking positions.

CERTIFICATION AND COMPLIANCE WITH REGULATIONS FOR THE PROTECTION AND SAFETY IN THE WORKPLACE

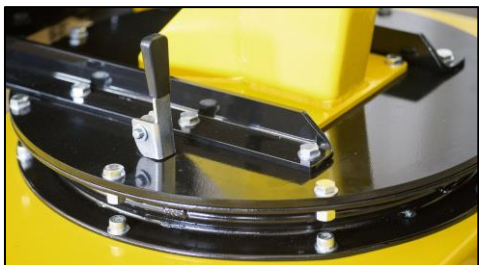

01B2SE_1000
CAPACITY 200 KG
COUNTERBALANCED SWIVEL CRANE , POWERED LIFT /LOWER & POWERED EXTEND/RETRACT JIB ARM WITH PROGRESSIVE SPEED



Technical data	UM	01B2SE_1000
Weight	[kg]	480
Max capacity	[kg]	200
Max pressure	[bar]	50
Tank capacity	[Liters]	2,5
Cylinder stroke	[mm]	470

Model 01B2SE_1000 is equipped with an electric controlled jib arm . It is equipped with a 4 way fine control lever controls for :

- Lifting the jib arm
- Lowering the jib arm
- Extending the jib arm
- Retracting the jib arm

All movements (arm and extension) are electric controlled, progressive and adjustable by the operator with extreme precision.

Controlled descent system with the engine off.

CAPACITY AND DIMENSIONS WITH STANDARD JIB ARM	
Length	Capacity
[mm]	[kg]
from 410 to 1410	from 200 to 80

Model 01B2SE_1000, being a crane with a maximum capacity of 200 kg, does not require a third-party certification according to current legislation.

CAPACITY WITH OPTIONAL EXTENDED JIB ARM	
Length	Capacity
[mm]	[kg]
from 1410 to 1910	Fix capacity 40

1 battery	[V]	12
	[A]	80
Battery charger	[V]	220
	[A]	12

Detail of the 4 way fine control lever



01B2SE_1000
TECHNICAL DRAWINGS & DIMENSIONS
The mini crane with a footprint of 790 mm

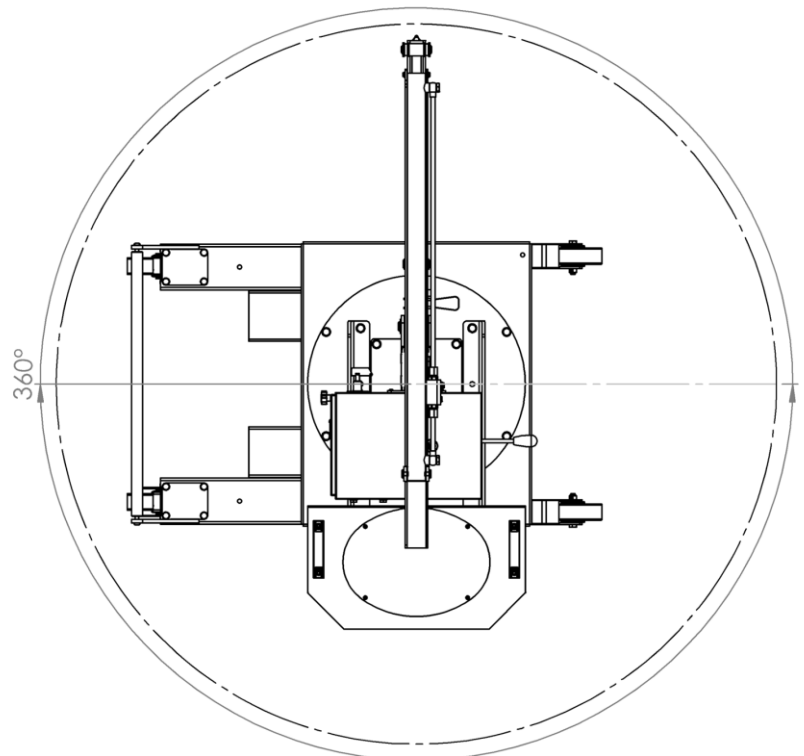
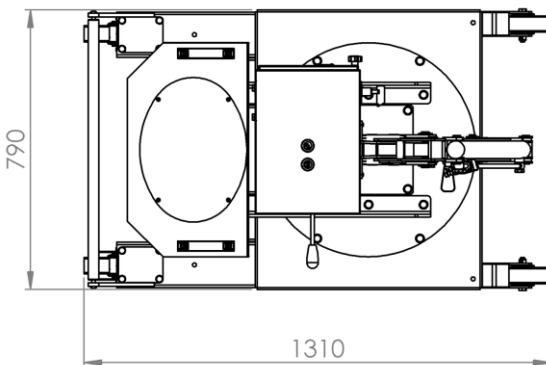
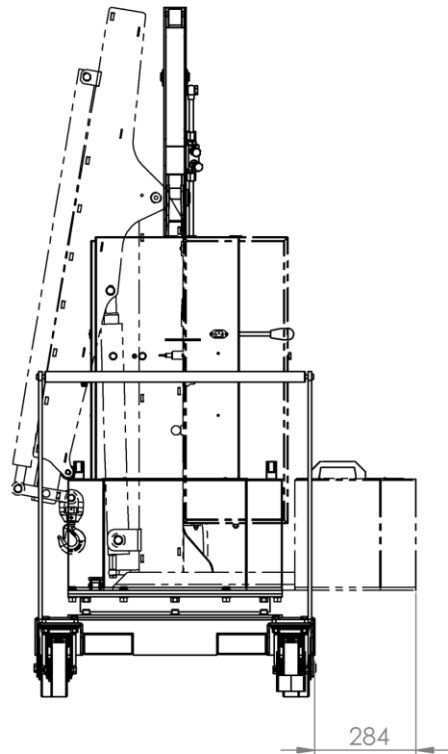
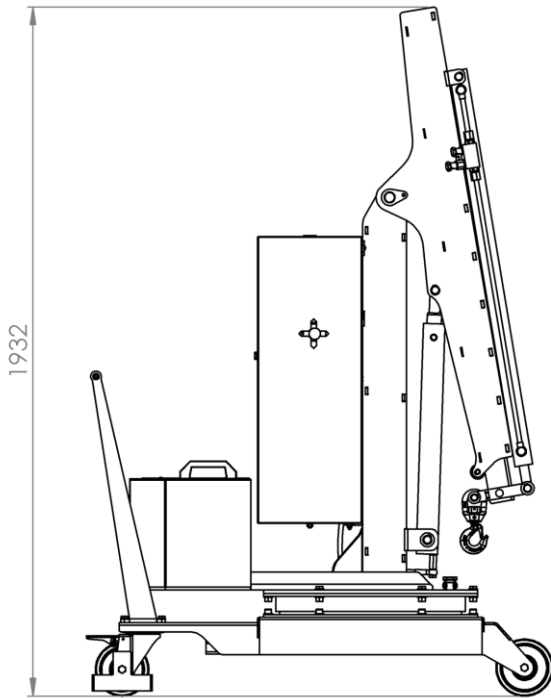

01B2SE_1000
CAPACITY 200 KG
LOADING CHART

