

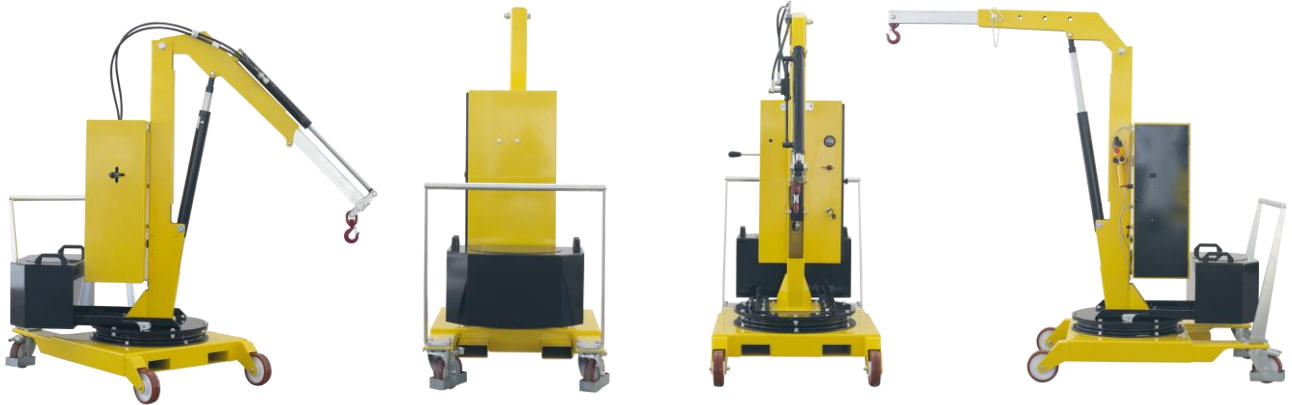

Flexibility, innovation and safety for your work

COUNTERBALANCED 360° SWIVEL CRANES



A complete range of counterbalanced 360° swivel cranes with manual traction, , **with a maximum capacity up to 500 kg and outreach up to 1300 mm**. Hydraulic lever controlled or electric controlled. They represent the most cost-effective and flexible solution for lifting and transporting loads in several applications such as machining centers and machine tools, delivery to assembly lines, assembly operations, goods handling. Thanks to their compact dimensions they are easily maneuverable even at full load and can be moved effortlessly in confined spaces. All components are made in Italy to ensure the highest construction quality and the absence of defects.

The hydraulic system is equipped with a lock valve that prevents the load from falling in case of accidental breakage of the pipes and a rough valve that prevents overloading of the crane.

They are equipped with 2 high-capacity pivoting wheels with bumper mounts and parking brakes and with 2 fixed front wheels with bearings. The frame is made of painted steel and is equipped at the base with 2 useful forklift supports (to lift and transport the crane in complete safety on long distances). The sturdy push handle can be disassembled. There are also 2 handles to easily rotate the ballast. Swivel hook type. Rotating Jib arm with 8 locking positions.

CERTIFICATION AND COMPLIANCE WITH REGULATIONS FOR THE PROTECTION AND SAFETY IN THE WORKPLACE

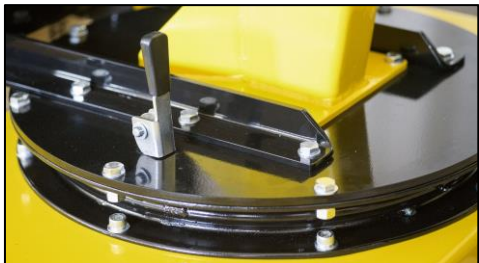

01B5P
CAPACITY 500 KG
COUNTERBALANCED SWIVEL CRANE, ONE SPEED LIFT/LOWER ELECTRIC
POWERED , LOWER CONTROLLED BY PENDANT PROGRESSIVE LEVER



Technical data	UM	01B5P
Weight	[kg]	640
Max capacity	[kg]	500
Max pressure	[bar]	140
Tank capacity	[Liters]	2,5
Cylinder stroke	[mm]	470

Model 01B5P is equipped with a pendant lever for lifting a load at a single speed and operating a progressive descent. This requirement is indispensable when millimeter accuracy is required during the positioning of the load.

The arm is extendable in 4 positions and an optional arm extension is available to get a maximum outreach of 1270 mm.

Built-in high-frequency charger. Charge level indicator. Battery 12V 80A.

CAPACITY AND DIMENSIONS WITH STANDARD JIB ARM		
POS.	Length [mm]	Capacity
		01B5P [kg]
1	365	500
2	500	420
3	635	370
4	770	320



CAPACITY WITH OPTIONAL EXTENDED JIB ARM		
POS.	Length [mm]	Capacity
		01B5P [kg]
1	865	220
2	1000	200
3	1135	180
4	1270	160

1 battery	[V]	12
	[A]	80
Battery charger	[V]	220
	[A]	12

01B5P

TECHNICAL DRAWINGS, DIMENSIONS AND CAPACITIES

Recommended for operations where an accurate load positioning is needed

STANDARD EXTENSION

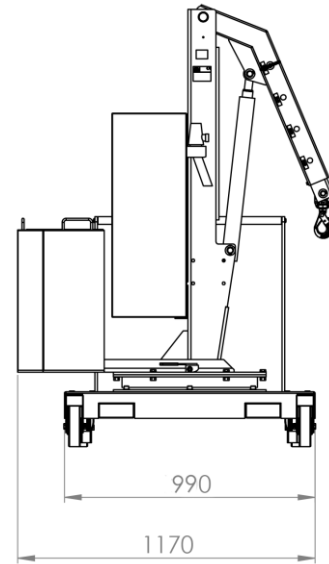
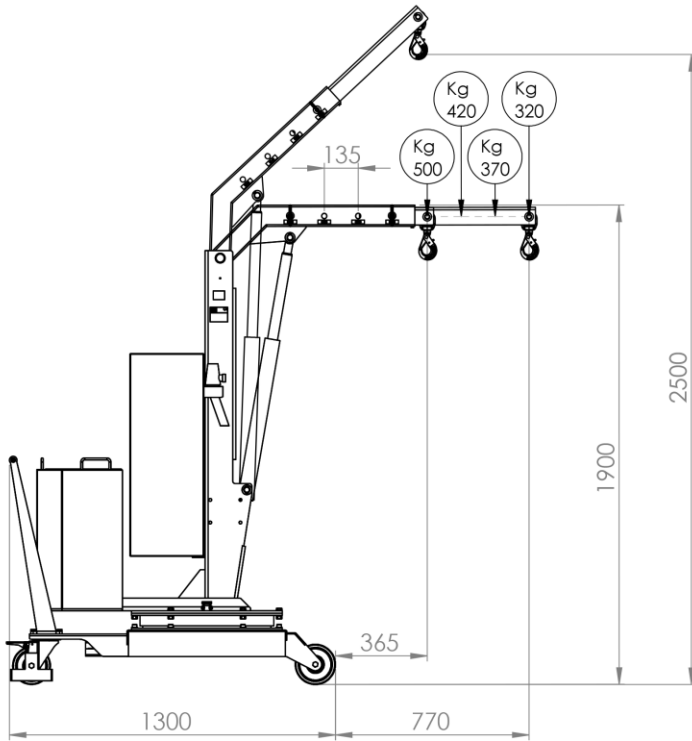

OPTIONAL EXTENSION

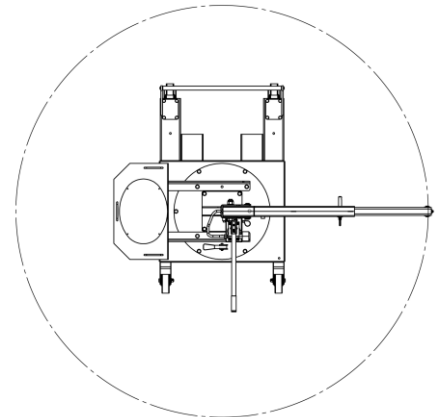
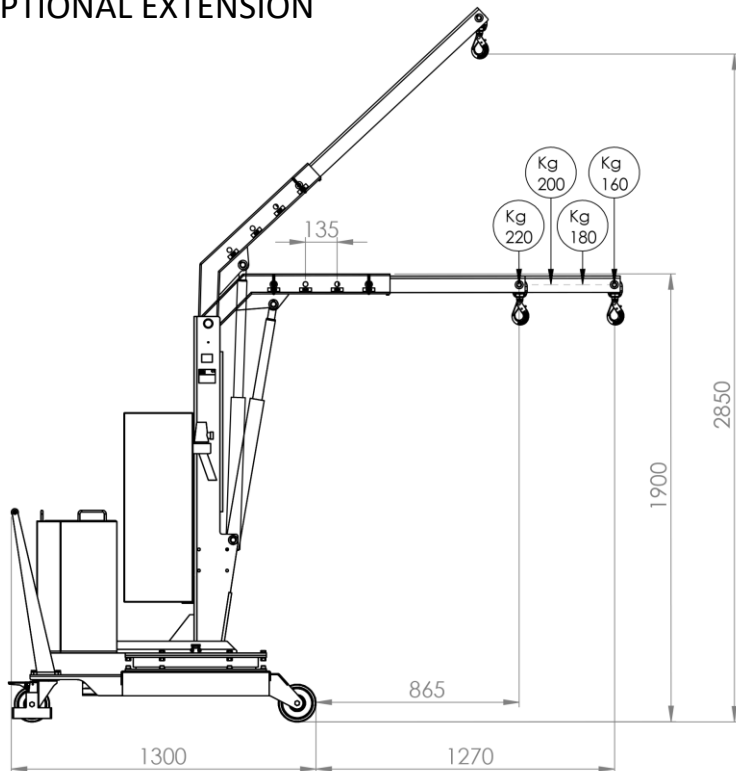

01B5P

TECHNICAL DRAWINGS, DIMENSIONS AND CAPACITIES

Recommended for operations where an accurate load positioning is needed

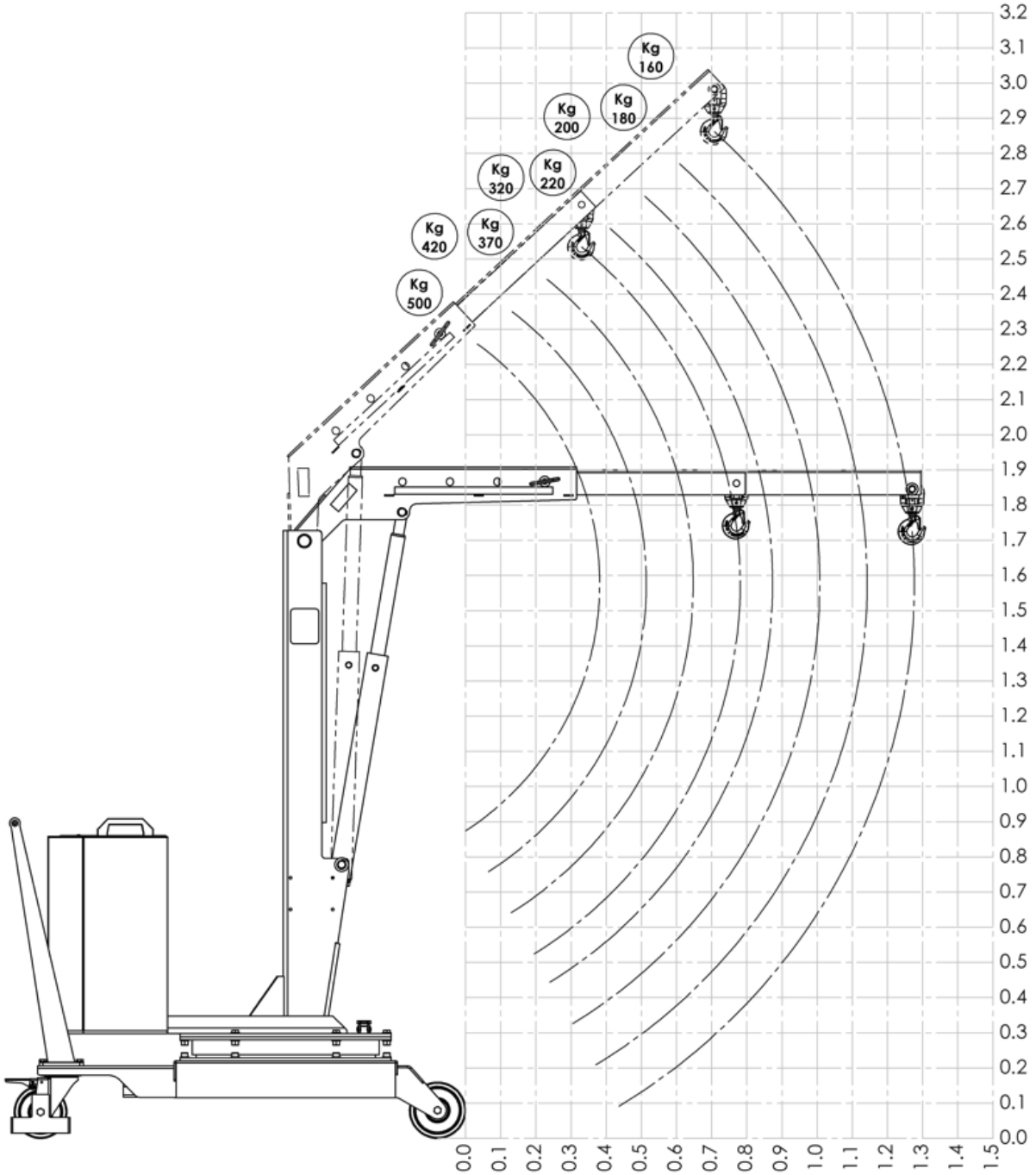



Flexibility, innovation and safety for your work

**A COMPLETE RANGE
OF COUNTERBALANCED 360° SWIVEL CRANES FOR ANY APPLICATION
SPECIAL CRANES AND CUSTOM PROJECTS ON DEMAND**

**IN COMPLIANCE WITH SAFETY REGULATIONS
TO ENSURE YOUR PRODUCTIVITY**



*We make value and safety
for your work*