

COUNTERBALANCED CRANES WITH FIX JIB ARM – MANUAL OR ELECTRIC CONTROLLED JIB EXTENSION – LARGE CAPACITY



A complete range of counterbalanced cranes with manual traction, , **with a maximum capacity up to 1.000 kg and outreach up to 2.000 mm**. Hydraulic lever controlled fast lift double action pump or electric controlled. They represent the most cost-effective and flexible solution for lifting and transporting loads in several applications such as machining centers and machine tools, delivery to assembly lines, assembly operations, goods handling. Thanks to their minimum frontal footprint of just 800mm they can be moved in narrow lanes and spaces and are easily maneuverable even at full load without efforts. All components are made in Italy to ensure the highest construction quality and the absence of defects.

The hydraulic system is equipped with a lock valve that prevents the load from falling in case of accidental breakage of the pipes and a rough valve that prevents overloading of the crane.

Tiller arm equipped with gas spring and double wheels Ø 200 mm with ball bearings and braking system; 2 fixed front wheels Ø 250 mm with bearings to make it easy to move.

The frame is made of painted steel and is equipped at the base with 2 useful forklift supports to lift and transport the crane safely on long distances. 360 ° swivel hook type.



CERTIFICATION AND COMPLIANCE WITH REGULATIONS FOR THE PROTECTION AND SAFETY IN THE WORKPLACE

GZ1000BSE

CAPACITY 1000 KG

COUNTERBALANCED CRANE , FIX JIB ARM , POWERED LIFT /LOWER & POWERED EXTEND/RETRACT JIB ARM WITH PROGRESSIVE SPEED



Technical data	UM	GZ1000BSE
Weight	[kg]	1195
Max capacity	[kg]	1000
Max pressure	[bar]	160
Tank capacity	[Liters]	3
Cylinder stroke	[mm]	550

CAPACITY AND DIMENSIONS WITH STANDARD JIB ARM	
Length	Capacity
[mm]	[kg]
from 650 to 1250	from 1000 to 500

CAPACITY WITH OPTIONAL EXTENDED JIB ARM	
Length	Capacity
[mm]	[kg]
from 1400 to 2000	FIX CAPACITY 200

1 battery	[V]	12
	[A]	80
Battery charger	[V]	220
	[A]	12

La GZ1000BSE is equipped with an electric controlled jib arm . It is equipped with a 4 way fine control lever controls for :

- Lifting the jib arm
- Lowering the jib arm
- Extending the jib arm
- Retracting the jib arm

All movements (arm and extension) are electric controlled, progressive and adjustable by the operator with extreme precision. Controlled descent system with the engine off.

Model GZ1000BSE is the most popular model for awkward placements from the ground onto 3D machines, lathes, over perimeter protections, narrow openings, etc. and in all those applications where there is no space to move the load with a forklift or other large sizes lifting equipment.



Battery charger



Detail of the 4 way fine control lever

GZ1000BSE

TECHNICAL DRAWINGS, DIMENSIONS AND CAPACITIES

The right crane for endless applications
and the best performance

STANDARD EXTENSION

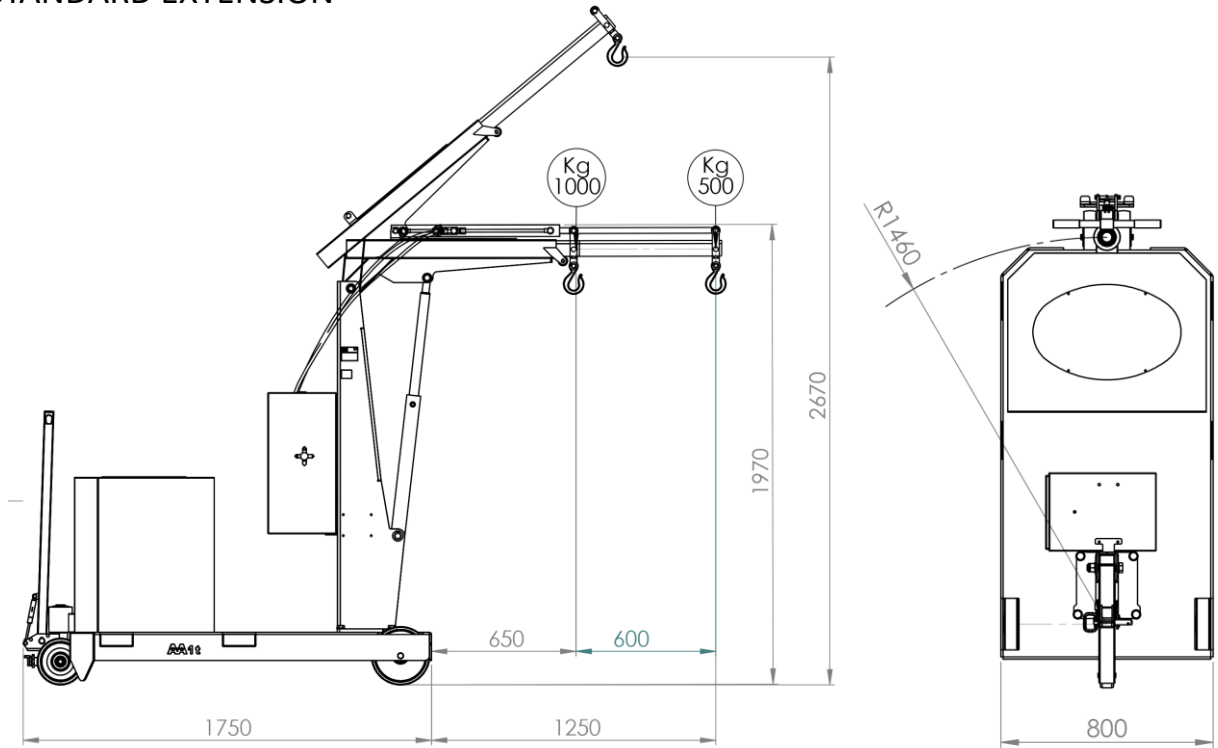

OPTIONAL EXTENSION

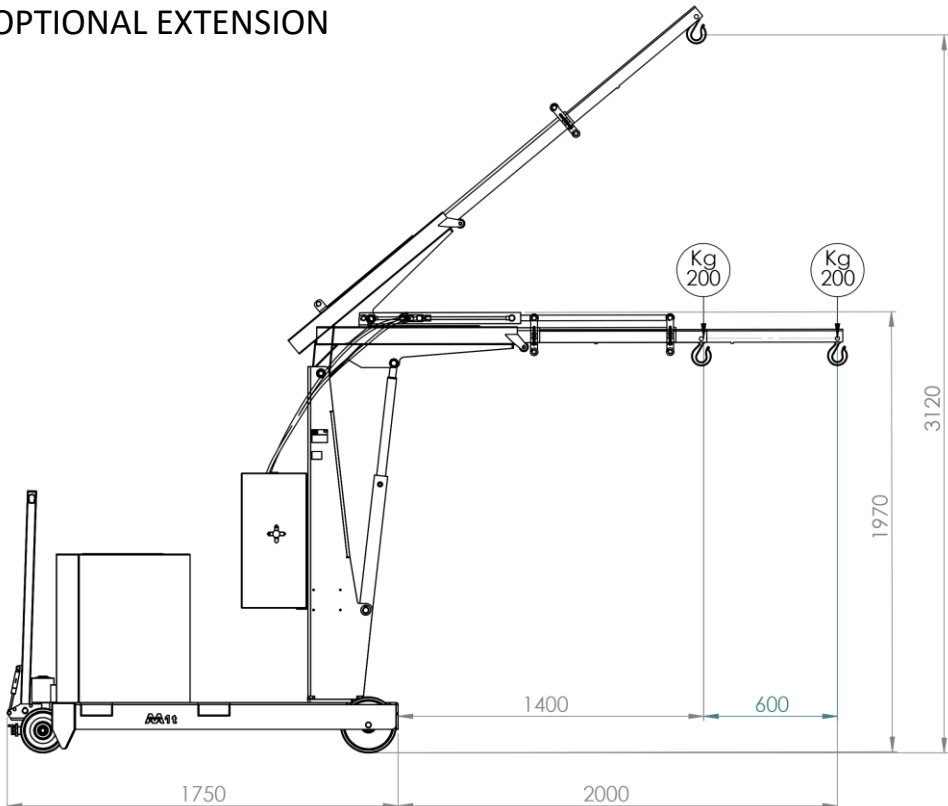

Powered
lift/lower and
powered
extend/retract jib
arm with
progressive
speed

GZ1000BSE
TECHNICAL DRAWINGS, DIMENSIONS AND CAPACITIES
 The right crane for endless applications
 and the best performance

